

Operating, Field Maintenance, and Parts Manual



Model
998

General Safety Precautions

Never point the gun at anyone.

Inspect hose before each use for breaks or weakened spots.

Always shut off valve at tank when leaving the gun unattended for any length of time.

WARNING: DO NOT TOUCH WIRE METAL SHIELD AFTER GUN HAS BEEN FIRED.

Table Of Contents

- I. Introduction
- II. Which Bag To Buy
- III. Which Tank To Use
- IV. Ventilation Requirements
- V. Operating Instructions
 - A. Controls
 - B. Connections
 - C. Start-up
 - D. How To Shrink
 - 1. Pallets
 - 2. Patching
 - 3. Large Goods
- VI. Service Information
 - A. Principles Of Operation
 - B. Troubleshooting
 - C. Assembly and Disassembly
 - D. Technical Specifications
 - E. Parts Breakdown & Spare Parts

I. Introduction

The New SHRINKFAST Model 998 heat shrink tool has evolved from the previous models 975 and 305X. The major new features include cool combustor, lightweight, durable and safety/trigger mechanism that automatically shuts off if it should be dropped. The simple design allows for field repairs to be completed quickly and efficiently.

The manual has also evolved into a simplified format which, if read carefully, will greatly enhance the operator's skill in using the tool. In addition, every operator should be particularly aware of the safety requirements covered in Section III WHICH TANK TO USE and in Section IV VENTILATION REQUIREMENTS.

II. Which Bag To Buy

Bag makers can usually be found in the Yellow Pages under Packaging Supply Houses or Bags – Transparent. Salesmen are generally knowledgeable and can give you good advice, but you should keep the following facts in mind:

1. Not all plastic bags are shrink bags; therefore, be specific. Shrink film should always be made of virgin plastic, not reprocessed material.
2. Bags come in various thicknesses. The bag thickness is measured in mils. The most common is 5 mil. For light loads such as a load of cookies at 100 lbs./pallet, a 3 mil bag should be satisfactory. However, drums of molasses, for example, at 2000 lbs./pallet would require 6 mils or more.
3. Bags are made in two styles, centerfold and gusseted. Gusseted bags shrink equally in both directions (35%/45%) and are troublesome because they tend to pull up and

away from the pallet. Therefore, they should be bought longer than the pallet height, and special care should be taken in the bottom shrink. Centerfold bags shrink mostly in one direction around the pallet (60%/10%); therefore, they don't have a tendency to pull up off the pallet.

4. Bag dimensions are specified by the lay-flat length and width. Example:

To calculate the width, add:

- | | |
|----------------------|------------|
| 1. The two sides | 30" |
| | <u>47"</u> |
| | 77" |
| 2. Fitting allowance | 4" |

WIDTH	81"
-------	-----

To calculate the length, add:

- | | |
|-----------------------------------------------------|-----|
| 1. 1/2 of the short side | 15" |
| 2. The height | 36" |
| 3. Shrink allowance –
1" for each foot of height | 3" |

LENGTH	54"
--------	-----

In this case the bag size is 81" x 54".

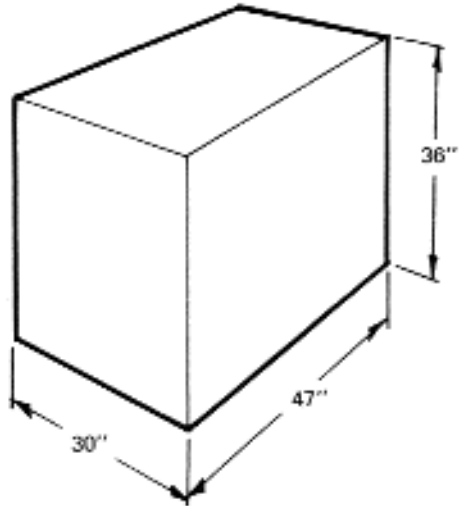

III. Which Tank To Use

Two types of tanks are commonly available: liquid withdrawal and vapor withdrawal. It is crucial to use the vapor withdrawal type. Never try to run the gun on a liquid withdrawal tank.

Using a liquid withdrawal tank will clog the orifice filter and may result in an extremely dangerous long flame.

Tanks are available in 6, 8, 10, 20, 30, and 40 lb. Sizes. The gun will run on a 6 lb. Tank if used only intermittently. Larger tanks should be chosen for continuous use.

Tank pressure depends on the temperature of the tank. At room temperature (72°F) the pressure is 110 PSI and drops to 22 PSI at 0°F.

When in use, the temperature of the tank drops due to the evaporation process of liquid propane to propane gas.

After prolonged use the temperature of the

tank may drop to 0°F usually accompanied by icing on the outside, and the propane pressure drops below 15 PSI. DO NOT RUN THE GUN WITH THE PRESSURE BELOW 15 PSI.

Small or nearly empty tanks ice up faster than large, full tanks. Typically, a full 30 lb. Tank, if run continuously, will run 90 minutes before it ices up. If the production rates demand continuous use, the following methods may be employed:

1. Multiple tanks. Switch the gun from one tank to another.
2. Fan. An ordinary desk Fan fan at the tank. The air flow around the tank will keep it from icing up.



RIGHT: Vapor Withdrawal Tank commonly used for plumbers torches, welding and cutting apparatus and camp and trailer stoves.



WRONG: Liquid Withdrawal Tank commonly used for Lift Truck or other internal combustion engines.

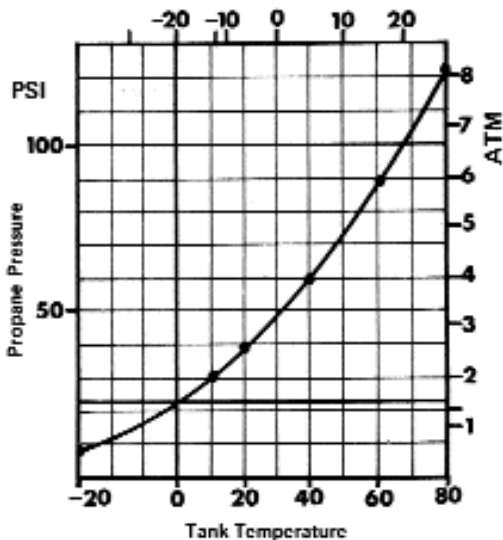

IV. Ventilation Requirements

In operation, the gun consumes propane and air and produces carbon dioxide, carbon monoxide, and water vapor.

Prolonged exposure to carbon monoxide is lethal and adequate ventilation must be provided if the gun is to be operated indoors.

The graph (right) shows measurements of the amount of CO generated (expressed as a percentage of the fresh air consumption of 20 cu. Ft./min.) as a function of flame adjustment:

The amount of CO generated depends on the flame adjustment, but does not exceed 0.25% within the limits of very rich and very lean. (By way of comparison, a 35HP forklift truck running on propane generated 6 times

as much CO).

To maintain a safe CO concentration of 50 parts per million (OSHA standards 1910.93), the ventilation requirements are 2000 cu.ft./min. while the gun is operated at the maximum operating pressure of 30 PSI.

Based on a 1 1/2 minute heating cycle per pallet, the fresh air requirements are 3000 cu.ft./pallet. For a production rate of 10 pallets/hour, a ventilation system with a continuous capacity of 500 cu.ft./min. is adequate. For different production rates, the ventilation capacity should be sized proportionally.

In areas where ventilation is provided by open doors or windows, a safe level of CO will be maintained as long as the room temperature does not rise above 150°F.

A. Controls

No.	Part	Function
1	Safety Trigger	Prevents accidental gas release
2	Gas Handle	Actuates gas valve and igniter
3.	Gas Valve	Open fuel flow
4.	Igniter	Fires piezoelectric spark igniter
5.	Fuel line	Carries fuel to orifice
6.	Filter	Prevents clogging
7.	Orifice	Meters fuel
8.	Spark Plug	Ignites mixture
9.	Flame Holder	Prevents flashback and flame out
10.	Hose	Connects regulator and gun
11.	Regulator	Regulates pressure to gun
12.	Adjustment screw	Sets pressure
13.	Pressure Gauge	Indicates pressure in the line
14.	Pol Fitting	Connects and contains excess flow check valve
15.	Tank	See section on tank
16.	Tank Valve	Opens/closes fuel supply

For ordering of spare parts, see page XX and XX.

B. Connections

Connect the gun, hose and regulator to the tank using a wrench to tighten the fittings which all have left hand threads.

To check for leaks, open the tank valve without actuating the gun handle to pressurize the hose. The pressure gauge should read between 15 and 30 PSI when the gun is not in use. Then close the tank valve and observe the pressure gauge. A rapid loss of pressure indicates a leak. Check all connections.

C. Start-Up

After all connections are made and checked for leaks, the gun is ready for use. Open the tank valve. Wait approximately 5 seconds to fully pressurize the hose or until the excess flow check valve opens with an audible click.

To start the gun, first press the safety trigger which prevents the gas handle from being accidentally opened. Then squeeze

the gas handle slowly all the way until the igniter fires with an audible click. CAUTION, GUN WILL IGNITE.

NOTES:

1. It is important to squeeze the gas handle slowly. If the gas handle is squeezed too quickly, the igniter will fire the spark plug before the gas mixture gets there.
2. Should the gun fail to fire fully, release both safety trigger and gas handle fully to assure that the igniter is reset and repeat the starting procedure.
3. The 998 heat tool comes complete with a variable regulator assembly. The tool will operate properly between 15 and 30 PSI. For thinner films, we recommend the setting to be on the low pressure side and adjust up to the 30 PSI level as the films get thicker. The factory setting is preset at 22 PSI.

D. How to Shrink

1. Palletizing

Your SHRINKFAST gun consumes oxygen and must be used only in well ventilated areas.

WARNING: DO NOT OPERATE GUN IN AREAS WITH FLAMMABLE GASES OR WHERE SMOKING IS PROHIBITED.

- a. Elevate the pallet load approximately 6 inches from the floor, leaving the undersides of the four corners unobstructed.
- b. Fit the pallet bag over the load, taking care that the film is not punctured as it is pulled into place. The bag should fit snugly over the goods and overhand the base of the pallet almost to the floor.
- c. To bottom shrink, ignite the gun and hold it approximately 12" from the film surface. Move once around the pallet applying heat to the bottom edge of the bag and using the air velocity to blow it under

the pallet. Shrink it so that it grasps the underside of the pallet firmly. In so doing, the bag is locked to the pallet, thereby unitizing the load.

d. To side shrink, do one side after another. Hold the gun approximately 12" from the film surface; shrink the side by sweeping the gun smoothly across the bottom. Move up a foot and sweep back and continue sweeping across the face moving up with every sweep until the side is finished. You will see the film wrinkling ahead of the gun as the film behind commences to shrink. It is important that the gun be kept in motion at all times. The action is very similar to spray painting.

As one side is completed, move to the next, each time commencing at the bottom and working your way up as you sweep from side to side.

e. The top of the pallet is shrunk last and requires less heat than the sides. This is

due to it already having been pulled taut through shrinkage of the four sides.

f. The pallet is now ready for shipment. Lift truck forks may be driven through the film where it covers the wooden pallet; the punctures will not propagate.

NOTES:

The most important fact to keep in mind is that heat only softens the film. The greatest amount of shrinking occurs as the film cools. It is a common fault of the inexperienced operator to apply too much heat to the film often concentrating the heat and waiting for the film to shrink before moving the gun.

Keep the gun moving.

With a little practice, you will find you can hold the gun closer to the film and sweep faster often shrinking a pallet in less than 2 minutes.

It is absolutely necessary that the four corners of the bag be caught under the pallet.

If this is not done, the effectiveness of shrink palletizing is considerably reduced.

2. Patching

Occasionally, holes will appear in the film. These may be easily patched by laying a square of film over the hole and applying heat around the edges welding the patch to the bag. The same technique may be applied to reinforce edges or corners with patches.

3. Shrink Wrapping Large Or Odd Shaped Loads

Shrink wrapping is a versatile method which may be employed in a great variety of applications. For example, shrink wrappers routinely wrap irregular objects such as canoes using sheets of shrink film.

Objects which are too big to fit under a bag may be wrapped by using several sheets of shrink film joined together if the following two precautions are observed:

Adjoining sheets should have an 18" overlap. This overlapping allows the sheets to weld together during the shrink process.

The sheets must be secured at the base of the load using the weight of the load or by battens tacked to the skids or any other method that may be expedient.

NOTE: SHEETS SHOULD BE JOINED TOGETHER ON THE FLOOR WITH AN 18" OVERLAP.

IV. Service Information

Note: Letters Keyed To Text On Following Pages.

A. Principles Of Operation

The SHRINKFAST 998 introduces a significantly improved jet pump based on using a multiple nozzle orifice (patents pending). The jet pump is shorter and more efficient with the benefits of a wider and more powerful heat pattern. Like the Model 975, it is basically a simple jet engine, the high energy exhaust of which is used to pump and heat the surrounding air and deliver an air blast of high velocity and moderate temperature. Its effectiveness is based on the high level of technical development which has gone into optimizing each stage of operation:

- 1. Jet Pump.** The propane jet (A) draws the correct amount of combustion air through the air inlet (B). They mix together in the straight section (C).
- 2. Compression.** The conical section (D) turns speed into pressure.
- 3. Combustion.** The combustion process is carried out inside the combustor (E). The

flame holder (F) prevents flashback (where the flame travels back into the jet pump) and the flame out (where the flame is blown out of the combustor). Another proprietary function of the flame holder is to achieve the unusual effect of maintaining cold combustor walls in spite of the fact that the combustion is substantially completed inside the combustor. This it does by imparting a swirl to the mixture. During combustion, the burned portion of the mixture expands, and its density diminishes. The swirl centrifuges the unburned, heavier portion outward and thereby creating a blanket of cold mixture along the walls. As combustion proceeds, the process draws from the protective layer of unburned mixture, and when combustion is completed the cooling effect stops. The size of the combustor ensures that for rated flow the point of completion coincides with the outlet. At less than rated flow, the blanket of unburned mixture does not extend all the way to the outlet and results in a red hot

combustor outlet.

4. Expansion. By virtue of the internal combustion process at elevated pressure a portion of the heat energy is converted to exhaust gas velocity. The gasses are expanded into the atmosphere through the combustor (E) with a velocity of over 160 MPH and a noticeable amount of thrust.

5. Entrainment. A second jet pump effect is created by the exhaust gases as they leave the combustor. The slot shaped outlet of the combustor creates a large mixture interface and promotes high volume entrainment within an unusually short distance. The exhaust gases transfer their heat and momentum to the entrained air and thus create a stream of high volume, low temperature air. This pumping effect is progressive, i.e. as the distance from the combustor increases so does the volume of air entrained. Since the heat and momentum are distributed over all the entrained air, the

temperature and velocity of the output decrease as a function of distance away from the gun.

B. Troubleshooting Guide

The majority of the problems arise from using a liquid withdrawal instead of a vapor withdrawal tank.
CHECK THIS ITEM FIRST.

PROBLEM

PROBABLE CAUSE

REMEDY

Gun won't fire

Handle not depressed fully.

Depress handle all the way until igniter fires with a click.

Handle activated too quickly.

Squeeze handle slowly to make sure mixture has entered combustor before firing.

Pressure too low.

Check Regulator

Handle not released fully.

Release both triggers to make sure igniter is reset.

Spark plug gap too small.

Open gap to 3 mm.

Defective igniter or connections.

Check for spark. Return for service.

Gas not on.

Check ON/OFF valve.

Combustor turns red* - (insufficient fuel flow)

Wrong fuel.

Check for proper type.

Tank has iced up and tank pressure is below 15 PSIG.

Change to new tank.

Excess flow check valve not open.

Open tank valve and wait 10 secs. Until hose is pressurized before using gun.

Continued on next page

Troubleshooting Guide continued

PROBLEM	PROBABLE CAUSE	REMEDY
Large Flame fuel flow)	Clogged orifice and/or filter	Remove and clean with compressed air.
	Clogged hose.	Blow out or replace.
	Clogged fuel line.	Blow out or replace.
	Leak in orifice assembly.	Tighten orifice in holder and check.
	Wrong pressure.	Reset to 15-30 PSIG.

*Leading edge of combustor will turn red under normal conditions. If more than 1" of combustor turns red trouble is indicated.

C. Assembly & Disassembly

GENERAL NOTES

1. Grease all "O" rings to facilitate assembly.
2. Fitting (23) is glued permanently into the valve body (22).

1. Filter Cleaning

- 1.1 Unscrew filter holder (1) using a screw driver or a coin. Pull out the filter holder.



- 1.2 Pull out the filter screen/spring assembly (3,4) and clean with compressed air or replace.



2. Spark Plug Replacement

- 2.1 Depress button (31) and remove combustor assembly (30)



- 2.2 Pull spark plug (28) and flame holder (32) out with a pair of pliers.





2.3 Unscrew spark plug. Note: spark plug gap should be set to 3-5mm.

3. Igniter Replacement



3.1 Undo the 5 mounting screws (29) and remove right housing (15).

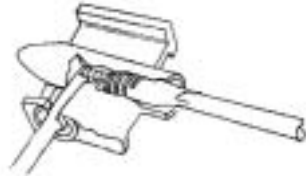

3.2 Undo contact screw (25) which retains the cable (17,18) and the contact spring (26)



3.3 Snap off the clamp (34) with a screw driver.



3.4 Pull out cable (9)



3.5 Untie and remove the ground strap (12)



3.6 Trigger/assembly (13) can now be lifted out.

4. Orifice Replacement

IMPORTANT NOTE: The orifice (14) consists of 6 slender, thin walled tubes which can easily be bent or damaged if dropped or mishandled. Once bent, the performance of the gun can be seriously impaired. For this reason the following operation should be performed with utmost care.

4.1 Remove the right housing (7) as shown in operation 3.1



4.2 Undo the 3 mounting screws holding the pump (14) and remove the pump first by sliding it away from the orifice and then lifting it out. This sequence is important because the orifice reaches inside the pump. Lifting the pump before sliding it away will damage the orifice tubes.



4.3 Unscrew the orifice



4.4 Use a .6mm drill to clean out each orifice stem.

UL Gun Only

5. Safety Cage Mounting



5.1 Push both curved tubular joins (15) onto one half of the cage (16).



5.2 Insert the second half of the cage (17) into the tubular joints and twist it together

fully until the mounting struts of both halves are parallel.

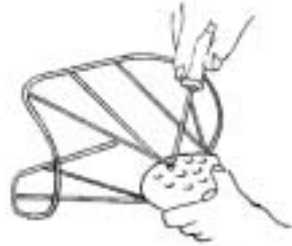

5.3 Attach the cage assembly to the combustor with the 4 mounting screws (18).

D. Technical Specifications

OUTPUT CHARACTERISTICS

DISTANCE/FT.	TEMPERATURE/°F	VELOCITY - FT./MIN.
1/2	1120	2100
1	650	1200
2	390	660
Heat Capacity		172,500 Btu./Hr.
Propane Consumption		8.0 Lbs./Hr.
Operating Pressure		22.5 PSIG
Weight		2 Lbs. 20 Oz.
Air Consumption		30 CFM
Emission		.015 CO/CO ₂

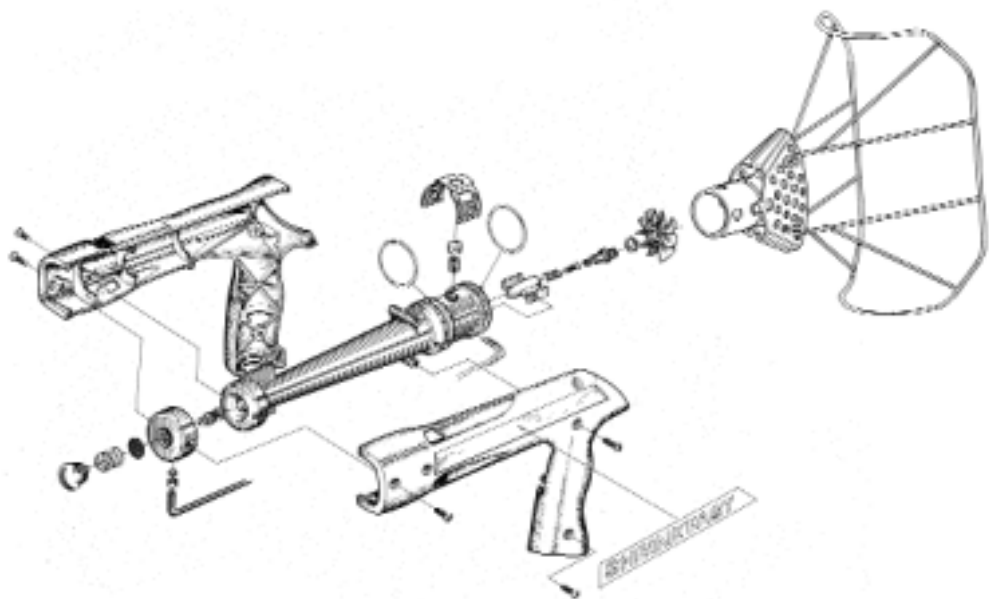

1. Filter Holder
2. O ring
3. Filter (disc)
4. Filter Spring
5. Orifice Assy.
6. 24-O ring
7. Retainer
8. Inlet
9. Fuel Line
10. Pump Body
11. Label, RH
12. Label, LH
13. Name Plate, UL (Not shown)
14. Name Plate, Euro (Not shown)
15. Housing, RH
16. Housing, LH
17. Trigger/Igniter Assy
18. Trigger/Igniter Assy
20. Safety
21. Spring
22. Valve Assy
- 23A. Hose Adapter-US
- 23B. Hose Adapter-Met.
25. Contact Screw
26. Contact Spring
27. Socket
28. Spark Plug
29. Assy Screws
30. Combustor
31. Button
32. Flameholder
33. O ring
34. Strap
35. Button Spring
- 36A. Hose Assy-US (Not shown)
- 36B. Hose Assy-Metric (Not shown)
37. Regulator Assy-US (Not shown)
37. Regulator Assy-Metric (Not shown)
37. Regulator Assy-Nul
40. Metal Box (Not shown)
41. Guard Screw
- 43A. UL Guard
- 43B. Euro Guard
- 44A. Wrench-US (Not shown)
- 44B. Wrench-Euro (Not shown)